



City of
Kelowna

SALT & BRICK

MOO-LIX
PREMIUM ICE CREAM

Jicks

LL22-0007
5800 Lapointe Drive
Liquor License Application

Purpose

- ▶ To seek Council's support for a new Liquor Primary License for the KF Aerospace Centre for Excellence

Development Process



April 28, 2022

Development Application Submitted



Staff Review & Circulation



May 9, 2023

Tuesday Council Meeting



Council Consideration



Recommendation Forwarded to LCRB

Context Map

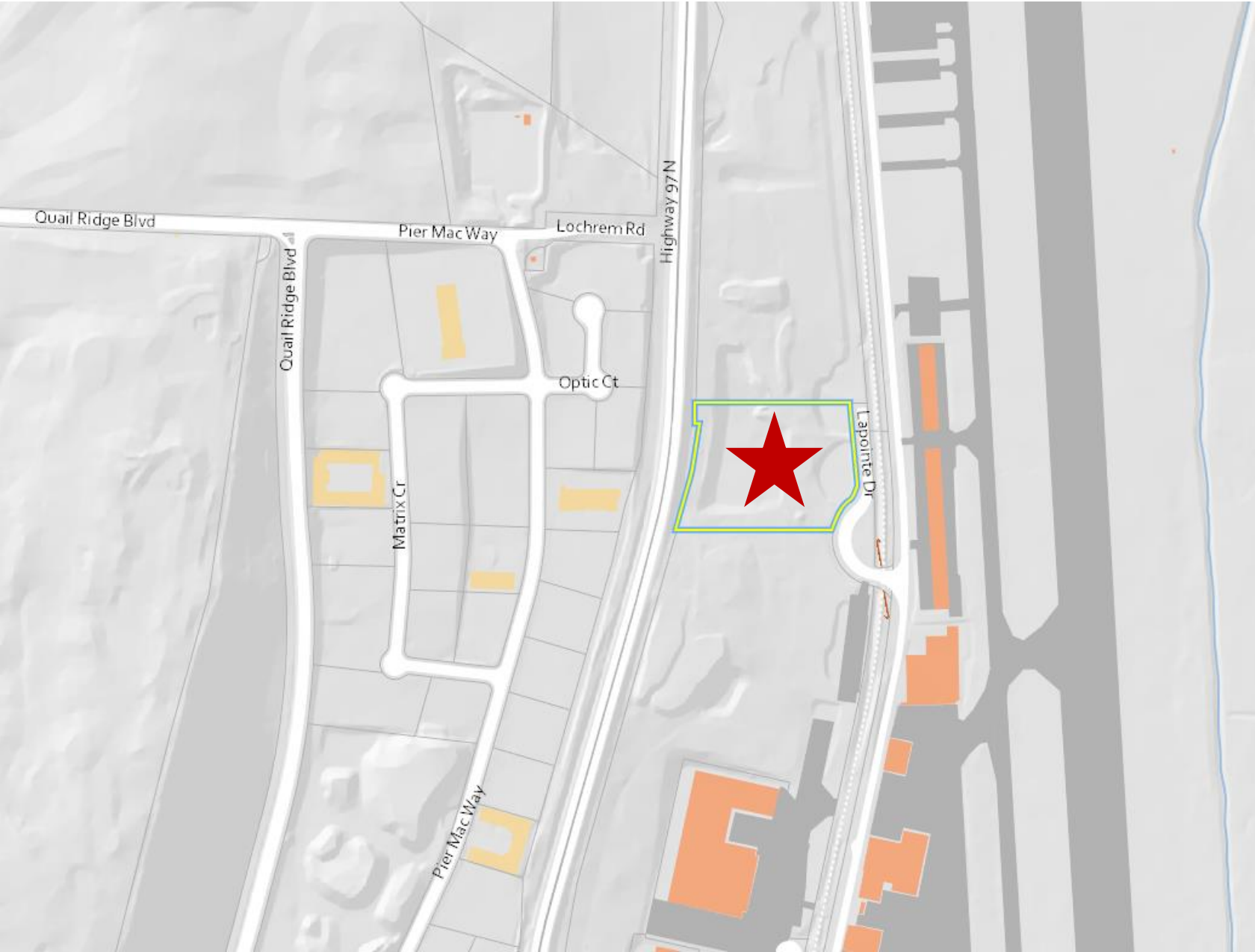

Walk Score
1

Transit Score
24

Bike Score
33



Subject Property Map

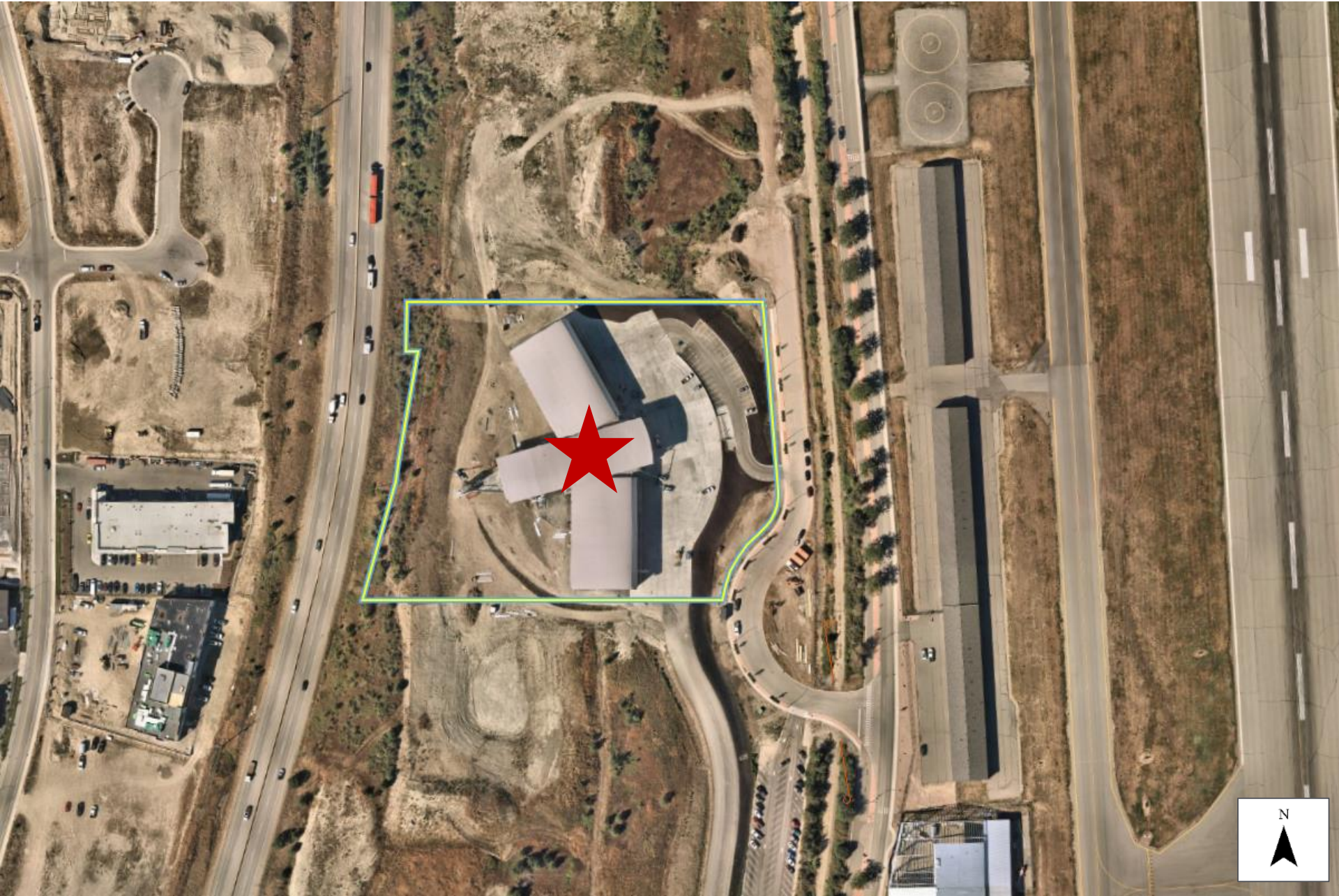

Hours of Sale & Occupant Load

Proposed Hours of Sale:

	Sun	Mon	Tues	Wed	Thurs	Fri	Sat
Open	12:00 PM	12:00 PM	12:00 PM	12:00 PM	12:00 PM	12:00 PM	12:00 PM
Close	5:00 PM	5:00 PM	5:00 PM	5:00 PM	5:00 PM	5:00 PM	5:00 PM

Proposed Occupant Load:

	Proposed
Occupant Load	127

Floor Plan

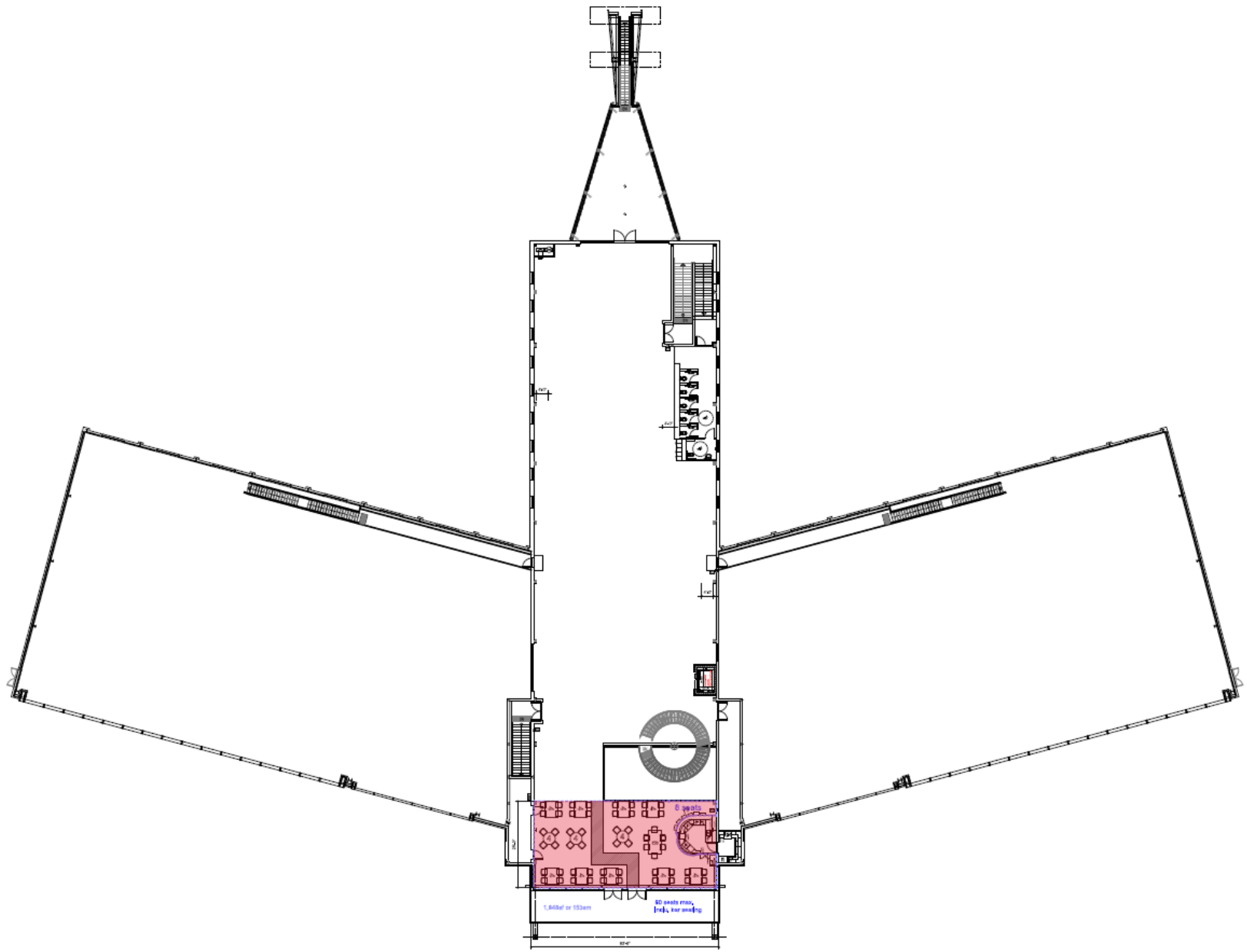

Council Policy #359

- ▶ Medium establishments: capacity between 100-249 persons
 - ▶ Should only be located within an Urban or Village Centre
 - ▶ Should be located a minimum of 100 m from a Large or Medium establishment
- ▶ Support establishments which are less focused on alcohol consumption
- ▶ Neighbourhood notification completed by delivering a letter to properties within 50 m

Staff Recommendation

- ▶ Staff recommend **support** for the proposed liquor license as:
 - ▶ Secondary to the aviation museum and conference facility
 - ▶ Location is appropriate due to the connection with the airport
 - ▶ Proposed hours and adjacent land uses mitigate impacts on the surrounding community
 - ▶ Council Policy No. 359 recommends supporting establishments which are less focused on alcohol consumption
- ▶ That Council directs Staff to forward a resolution of support to the LCRB.